

 **CLIPSAL**[®]

by **Schneider** Electric

C-Bus[®]

DALI Gateway

5502DAL



Programming Guide

Contents

1.0 Introduction	3
1.1 Description	3
1.2 Definitions.....	4
2.0 Concepts	5
2.1 C-Bus.....	5
2.2 DALI.....	6
2.3 C-Bus to DALI Address Mapping	7
3.0 Wiring Notes	7
4.0 Messages	9
5.0 Setup.....	9
5.1 DALI Setup.....	9
5.2 C-Bus Setup.....	10
6.0 Scenes.....	10
7.0 Specifications.....	11
8.0 Standards Complied.....	12
9.0 Two Year Warranty.....	13

1.0 Introduction

This Programming Guide provides basic set-up information for the C-Bus DALI Gateway. For additional information refer to C-Bus Toolkit software Help. Installers should contact the supplier of the Digital Addressable Lighting Interface (DALI) equipment to obtain the programming and commissioning software for DALI devices.

1.1 Description

The DIN rail mounted unit is normally installed inside an enclosure. The unit takes up 4M of space on a DIN rail. The C-Bus DALI Gateway uses RJ45 sockets for C-Bus connectivity. The unit has two C-Bus status indicator LEDs labelled Unit Comms and C-Bus.

Catalogue Number	Description
5502DAL	C-Bus-to-DALI Gateway, DIN rail mounted, provides communication between one C-Bus network and two DALI networks

Table 1. Product catalogue number and description

The DALI Gateway draws 32mA from the connected C-Bus network. The unit does not provide power to either the C-Bus network or the DALI networks. The gateway does not require mains power to operate.

The DALI specification is a communications protocol for controllers and electronic lamp ballasts. The DALI specification, developed by ballast manufacturers, includes a description of the electrical characteristics of the signal, and defines a protocol for the messages that will pass between controllers and ballast units.

The 5502DAL C-Bus-to-DALI Gateway provides an interface between a C-Bus network and up to two DALI networks and enables the two network types to interact with each other. The older gateway units were pre-programmed with a C-Bus to DALI and DALI to C-Bus addressing structure. The current model 5502DAL Gateway is programmed using Toolkit software that is downloaded free from the Clipsal CIS website.

Using C-Bus, the DALI gateway controls and monitors DALI compatible ballasts and ELV transformers (from various ballast manufacturers) over the C-Bus network. DALI power supplies are not provided with the DALI Gateway.

1.2 Definitions

The following definitions are useful in discussing the DALI Gateway:

Term	Definition
C-Bus Load	Any device connected to an electric circuit that consumes power controlled by a C-Bus Output Unit (examples are lights and electric motors).
C-Bus Output Unit	A device, such as a relay or dimmer, that directly controls electric loads.
C-Bus Input Unit	A device used to control loads (examples are key switches and passive infrared motion detectors).
Fade Rate	The time taken for a load to reach a certain level. Fade rate generally refers to light dimming.
Zones	Areas within a floor space may be divided up into zones.
Scene	A combination of loads to be controlled. Scenes may be relevant to zones and incorporate fade rates.
Application Address	C-Bus may be used for different uses or applications. Application addressing is a method to allow this.
Unit Address	Every C-Bus unit has a unique identity called a unit address. Each unit has an individual address so that the unit can be specified for various actions.
Short Address	An address used in DALI systems. Used in a manner similar to C-Bus Unit Addresses.
Group Address	Group addresses are identifiers that are programmed into C-Bus units to create associations between C-Bus input units and C-Bus output units, to control loads connected to the output units.

Table 2. Terms and definitions

Note: This document makes use of hexadecimal numbers that are prefixed by a dollar sign and followed by the decimal equivalent. For example, if we refer to the Hexadecimal Group Address 42, this is the same as decimal Group Address 66, and is written as \$42 (66).

2.0 Concepts

The C-Bus and DALI systems share many similar concepts. This similarity provides a basis for interconnecting the two systems. Before exploring the mapping between the two systems, it is worth summarising the basic concepts in the two systems.

2.1 C-Bus

C-Bus is a microprocessor-controlled network system that uses Unshielded Twisted Pair cable (UTP, Category 5e). The system is highly flexible in the way it operates because each device communicating on C-Bus has its own inbuilt microprocessor. These devices are field programmed with Toolkit software to provide optimum performance in any installation.

Control messages come from input units such as key units, light level and passive infrared occupancy sensors. Messages are sent over the C-Bus network to output units such as relays and dimmers. These messages are used to control the loads connected to the output units.

Unit Addresses

All units on the C-Bus network have a unique identity code called a unit address. This code forms part of the messages sent to C-Bus, so that only one unit corresponding to that address responds. These messages are typically used to activate the operating variables of the C-Bus devices.

The unique unit address means that:

- As each C-Bus unit has its own microprocessor with non-volatile memory (EEPROM), it is possible through the unique unit address to individually program each unit.
- The unique unit address is then used by C-Bus to pass commands over the network to specific units with instructions on what to do.

In this way you can program individual units without removing them from the C-Bus network.

Application Addresses

An application address can identify devices on the C-Bus network. Units can be grouped together so that commands issued to that group will not affect other groups. For example, commands to execute scenes on the trigger control application will not affect a load on the lighting application. This grouping separates all lighting units from other types of units and commands.

Group Addresses

Within the lighting applications, group addresses are used to emulate the function of conventional wiring. The C-Bus addressing scheme allows you to have up to 255 groups. Each group is like a lighting circuit and can be controlled separately from any other group.

A group association is programmed into both input units (key inputs and sensors) and output units (relays and dimmers). Any message broadcast by the input units for that group are read by the output units that share the same group address. Loads are switched or dimmed as appropriate.

2.2 DALI

The DALI system uses both short addresses (analogous to unit addresses) and group addresses (very similar to the C-Bus concept) to achieve a flexible assignment of loads to inputs.

The main differences between DALI and C-Bus are in the actual implementation of group addresses and the nature of the commands broadcast over the DALI network.

DALI Group Addresses

The DALI units may have up to 16 group addresses each. This means that if a unit has groups numbered 1,2,3 and 4 associated with it then it will respond to a message addressed to group 1,2,3 or 4. Note that in a C-Bus system by comparison, a load can only have one group address.

DALI Lighting Commands

The DALI system supports many commands that turn a load on or off, ramp it or perform other functions. The controlled lighting ballast has a level and fade rate programmed into it. The level and fade rate apply to any ramp command received by the ballast, until such time as the parameters are changed by the DALI configuration software.

The level is not stored internally in the ballast, but the fade rate and fade time are. Also stored in the ballast are parameters like power on level and mode level. The current level is not stored, but is sent from C-Bus with each command.

There are two fade settings. The fade 'rate' and fade 'time.' The 5502DAL Gateway uses the fade time setting.

In a C-Bus system each ramp command contains instructions for the level and fade rate. A specified dimming ballast can generate the requested fade rate or level and repeat the operation in rapid succession, each time at a different fade rate and level.

2.3 C-Bus to DALI Address Mapping

A user-configurable table in the Toolkit GUI maps the addresses used by C-Bus and those by the DALI system. Refer to Toolkit Help for assistance in mapping C-Bus to DALI.

3.0 Wiring Notes

CAUTION

Do not tie the outputs of the DALI power supplies together. Damage to the supplies and the Gateway unit will occur.

Do not connect the DALI Gateway to mains power. The unit is powered from the C-Bus network. The Gateway unit does not supply power to the C-Bus network or to the DALI networks.

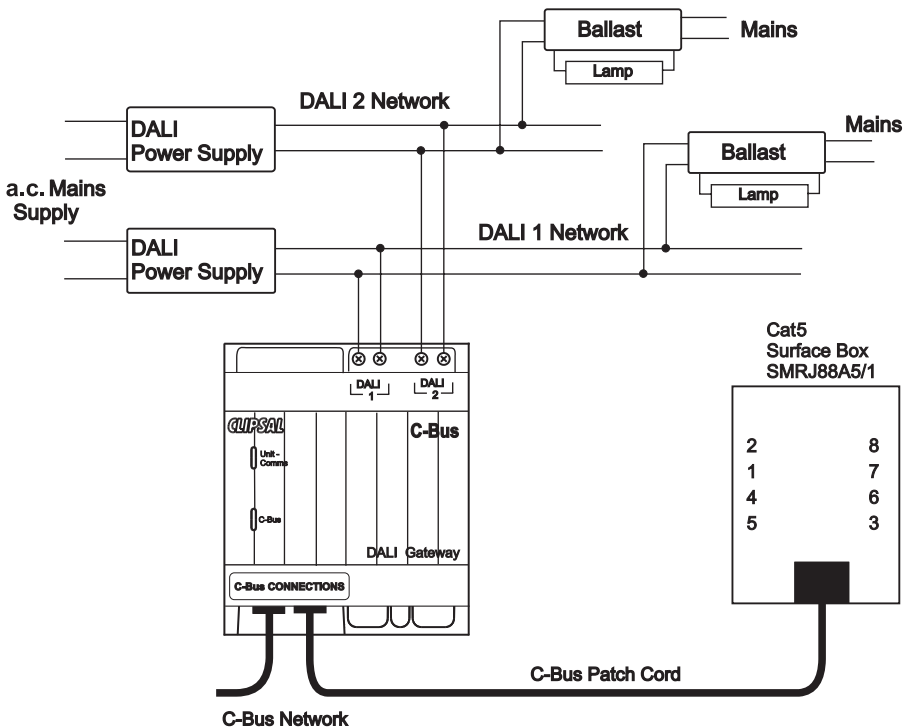

Figure 1. Wiring diagram

Two RJ45 connectors are provided for upstream and downstream network attachment. The C-Bus network uses pink Cat 5e, polarised 15-36 volt, twisted-pair cable, catalogue number 5005C305B (solid) and 5005C305BST (stranded).

RJ45 pin	Signal name	Wire Colour
1	Remote ON	green & white
2	Remote ON	green
3	C-Bus negative (-)	orange & white
4	C-Bus positive (+)	blue
5	C-Bus negative (-)	blue & white
6	C-Bus positive (+)	orange
7	Remote OFF	brown & white
8	Remote OFF	brown

Table 3. C-Bus network wiring colours codes

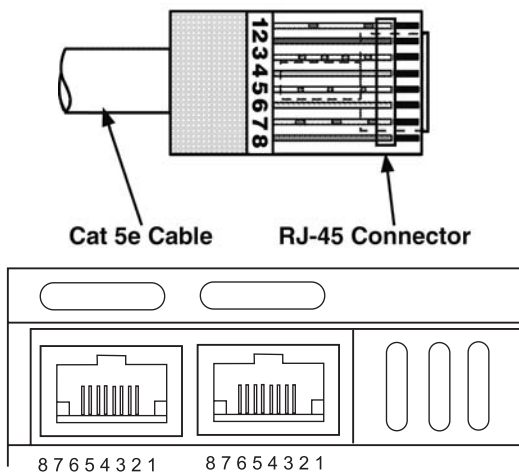

Figure 2. RJ45 pin assignments for plugs and sockets

Notes:

A maximum of 64 DALI devices can be connected on a single DALI network. Each DALI network must be interconnected with a maximum total wiring of 300m.

A maximum torque of 1.4 Nm should be applied to the screw terminals.

The wire used should be mains rated with double insulation and a minimum 1.5 mm² cross section.

A rubber plug is supplied to close off the unused RJ45 connector. Always ensure that the plug is installed. The plug stops foreign bodies and dust from entering the unit.

4.0 Messages

When a C-Bus command is sent on the C-Bus network to turn off a mapped group address this message will be transmitted by the DALI Gateway to the appropriate load on the DALI network. The converse is also true; a message on the DALI network can be translated and transmitted on the C-Bus network.

For example, if a key input unit is programmed to toggle Group Address \$42 (66), then DALI_1_GROUP2 will respond. Similarly, if something on the DALI network were to command DALI_1_GROUP2 to change, then a message to do the same thing appears on the C-Bus network for Group Address \$42 (66). So, an Off command on the DALI 1 Network to Group 2 makes the indicator on the key input unit turn off. Pressing the key input unit sends an On command back to the DALI network to Group 2.

Note: The values transmitted from the DALI Gateway are not stored anywhere in the C-Bus Network unless a C-Bus unit is programmed to that Group Address.

5.0 Setup

The hybrid systems relevant to the DALI Gateway product necessarily involve both DALI and C-Bus programming. The following sections touch upon the requirements.

5.1 DALI Setup

Initially, the DALI system will not contain any groups until they are programmed into the DALI units. DALI programming and commissioning software is sourced from the manufacturer of the ballasts being used.

The default behaviour of DALI units is to respond to Broadcast On and Broadcast Off commands. The DALI network is split into two halves: DALI 1 Network and DALI 2 Network.

The Group Addresses \$60 (96) and \$61 (97) correspond to DALI_1_BROADCAST and DALI_1_OFF. These addresses turn all the loads in DALI network A On and Off, respectively. Similarly the Group Addresses \$E0 (224) and \$E1 (225) correspond to DALI_2_BROADCAST and DALI_2_OFF.

To obtain finer control of the network, individual group addresses have to be applied to the DALI units. Although each DALI unit can contain up to 16 DALI groups, the simplest programming option is to provide only one group per unit.

This will provide 16 distinct lighting zones. For large commercial spaces this should be adequate.

5.2 C-Bus Setup

Program the C-Bus DALI Gateway using C-Bus Toolkit software that can be downloaded free of charge from the Internet.

To determine the C-Bus group addresses, refer to the DALI programming table. Since these are effectively fixed, we suggest that the DALI Gateway and any key input units associated with DALI be placed on another lighting application, such as \$39 (57) to avoid unforeseen interactions between DALI and any existing C-Bus lighting project.

6.0 Scenes

The DALI system provides for scenes by pre-programming each unit to be 'aware' of which scenes it participates in and setting a specified arc level for that scene. Sending the DALI_1_SCENE12, for example, will notify all units in that scene to carry out their programmed action.

The DALI scenes are quite independent of the groups and the units do not betray their membership in a scene in any remotely assessable way. The DALI scene message does not describe which units are involved, so 'listening in' on the DALI network traffic would not provide information about which loads are involved.

A C-Bus scene, on the other hand, includes both the scene triggering message (on the trigger control application) and the subsequent lighting messages (on the lighting application), so the relevant parts of the state of the system can be inferred from the messages.

In addition to this, C-Bus scenes can be actioned by numerous devices, such as Scene Master, Neo, Reflections, C-Touch, and software such as C-Gate. Any C-Bus input device anywhere on the network can trigger these devices and software.

In general, we recommend that scenes be implemented using C-Bus: the DALI network will participate in any scenes generated by C-Bus via the DALI Gateway. All monitoring software will be appraised of scene progress through the usual C-Bus techniques. Individual DALI keys can still be used provided they are programmed to address groups only. Any application address from \$30 (48) to \$5F (95) is a valid lighting address.

As mentioned above, scenes can be implemented using DALI, but unfortunately any monitoring package is 'blind' to what is going on over the network.

7.0 Specifications

Parameter	Value
C-Bus input voltage	15-36V d.c.
Current drawn	32mA from the C-Bus network. The gateway does not provide power to the network.
C-Bus AC input impedance	50k Ω at 1kHz
Electrical isolation	3.75kV RMS for one minute between C-Bus and the DALI networks
Maximum number of units on a single C-Bus network	50 units
Connections	C-Bus: 2 – RJ45 connectors
	DALI: 2 screw terminals per DALI network
Mounting type	DIN rail
Max.number of DALI addressable units	64 per DALI network
System clock and burden	Software selectable
Operating temperature	0° to 45°C
Humidity	10 to 95%, non-condensing
Weight	130 grams

The DALI power supplies are not provided with the DALI Gateway.

8.0 Standards Complied

The 5502DAL C-Bus DALI Gateway meets the following standards.

Australian/New Zealand EMC & Electrical Safety Frameworks and Standards



Regulation	Standard	Title
EMC	AS/NZS CISPR 22	Information technology equipment - Radio disturbance characteristics (EMC)
Safety	AS/NZS 61347-2-11	Particular requirements - Miscellaneous electronic circuits used with luminaires

European Directives and Standards



European Council Directive	Standard	Title
EMC Directive 2004/108/EC	EN 55022	Information technology equipment - Radio disturbance characteristics
	EN 55024	Information technology equipment - Immunity characteristics
Safety	EN 61347-2-11	Particular requirements - Miscellaneous electronic circuits used with luminaires
Low Voltage Directive 2006/95/EC		Lighting equipment - Electrical, mechanical, chemical and all other risks
RoHS 2002/95/EC		Reduction of hazardous substances

Other International Directives and Standards

Regulation	Standard	Title
EMC	CISPR 22	Information technology equipment - Radio disturbance characteristics
Immunity	CISPR 24	Information technology equipment - Immunity characteristics
Safety	IEC 61347-2-11	Particular requirements - Miscellaneous electronic circuits used with luminaires

9.0 Two Year Warranty

The 5502DAL C-Bus DALI Gateway carries a two year warranty against manufacturing defects.

Warranty Statement

The benefits conferred herein are in addition to, and in no way shall be deemed to derogate, either expressly or by implication, any or all other rights and remedies in respect to the Schneider Electric product, which the consumer has in the location where the product is sold.

The warrantor is Schneider Electric with offices worldwide.

This Schneider Electric product is guaranteed against faulty workmanship and materials for a period of two (2) years from the date of installation.

Schneider Electric reserves the right, at its discretion, to either repair free of parts and labour charges, replace or offer refund in respect to any article found to be faulty due to materials, parts or workmanship.

This warranty is expressly subject to the Schneider Electric product being installed, wired, tested, operated and used in accordance with the manufacturer's instructions. Any alterations or modifications made to the product without permission of Schneider Electric might void the warranty.

Schneider Electric shall meet all costs of a claim. However, should the product that is the subject of the claim be found to be in good working order, all such costs shall be met by the claimant.

When making a claim, the consumer shall forward the Schneider Electric product to the nearest Clipsal by Schneider Electric office. Provide adequate particulars of the defect within 28 days of the fault occurring. The product should be returned securely packed, complete with details of the date and place of purchase, description of load, and circumstances of malfunction.

For all warranty enquiries, contact your local Clipsal or Schneider Electric sales representative.

The address and contact number of your nearest sales office can be found at <http://www.clipsal.com/locations> or by telephoning Technical Support 1300 722 247 (CIS Technical Support Hotline, Australia).

Notes

Technical Support

For further assistance in using this product, consult your nearest Clipsal Integrated Systems (CIS) Sales Representative or Technical Support Officer.

Technical Support Contact Numbers	
Australia	1300 722 247 (CIS Technical Support Hotline)
New Zealand	0800 888 219 (CIS Technical Support Hotline)
Northern Asia	+852 2484 4157 (Clipsal Hong Kong)
South Africa	011 314 5200 (C-Bus Technical Support)
Southern Asia	+603 7665 3555 Ext. 236 or 242 (CIS Malaysia)
United Kingdom	0870 608 8 608 (Schneider Electric Support)

Schneider Electric (Australia) Pty Ltd

Contact us: clipsal.com/feedback

National Customer Care Enquiries:

Tel 1300 2025 25

Fax 1300 2025 56



F2255/01

clipsal.com

Schneider Electric (Australia) Pty Ltd reserves the right to change specifications, modify designs and discontinue items without incurring obligation and whilst every effort is made to ensure that descriptions, specifications and other information in this catalogue are correct, no warranty is given in respect thereof and the company shall not be liable for any error therein.

© 2011 Schneider Electric. All Rights Reserved.
Trademarks are owned by Schneider Electric Industries SAS or its affiliated companies.

CLIPCOM 23446 August 2011